

MODEL SG-40

Track Stump Grinder

Building on the success of its predecessors, the Bandit SG-40 is engineered to be the perfect machine for rental companies and dedicated stump grinding professionals who need to quickly move from site to site with efficiency. Featuring a new cutterwheel drive system, adjustable tracks, and an **industry-leading swing arc** for its size class, the cutting-edge design innovations of the SG-40 promise **more performance and productivity** when it comes to maneuvering within a challenging environment and grinding with confidence at the stump. And **intuitive controls** make operation easy, no matter if you're a seasoned professional or a rental customer.



COME OUT SWINGING

The Bandit SG-40 is a highly productive grinder that can aggressively track down and sweep away stumps with authority. A newly designed spindle and hub assembly promotes a long-lasting lifetime of oscillating motion and a new swing geometry extends the cutterwheel grinding width to a massive 47". With that type of coverage area, you're sure to spend more time grinding at the stump rather than repositioning.

STAYING ON TRACK

The SG-40 rides on durable rubber tracks that can take this machine across delicate lawns, rough terrain, or even rut-filled lot clearing sites. The tracks are vital for stabilizing the grinder at the stump, and are also now easily adjustable to keep proper tension. When the job is done, the tracks help the machine climb quickly into the trailer so you can get on to the next job.

INTUITIVE CONTROLS

Controls are mounted at the rear of the machine on a pivoting console, so no matter the position of the stump, you'll be able to get an excellent view of the grinding action. Control levers and instrumentation, including service points, have been designed with consideration for good, proper ergonomics that make the SG-40 a pleasure to run.

THE FORCE OF GRAVITY

The locations of tracks and tanks on the newly configured chassis of the SG-40 have been shifted to create a better center of gravity and wider distribution of weight. This helps to provide more power, force, and leverage especially on inclined surfaces or uneven chip piles. The amount of shock to components is also reduced with a smoother and more balanced ride over rough terrain.

POWERFUL EFI ENGINE

A 38 horsepower gasoline engine, featuring electronic fuel injection, is easy to start, operate, and control no matter your comfort level with small engines. It is an abundantly powered and proven unit for rental companies or professional grinders who want to focus on the job and not an engine.



Bandit INDUSTRIES, INC.

6750 Millbrook Rd. • Remus, MI 49340 • 1-800-952-0178

FIND US ONLINE     WWW.BANDITCHIPPERS.COM

All specifications, dimensions and options are subject to change without notice, and were current at the time of printing. Dimensions may vary, depending on options and engines selected. Bandit Industries, Inc. reserves the right to change designs, specifications and options without prior notice. © 2020 Bandit Industries, Inc. All Rights Reserved.

CALL YOUR LOCAL BANDIT SALES REPRESENTATIVE TO SCHEDULE A DEMONSTRATION TODAY!

SPECIFICATIONS

MEASUREMENTS

Length: *	100.5"	255.3 cm
Width:	29.5"	75 cm
Height:	48"	122 cm
Weight (lbs.):	1,500 lbs.	680.4 kg
Engine:	38 HP	28.3 kW
Fuel Tank:	7 gal.	26.5 L
Hydraulic Tank:	7 gal.	26.5 L

* Measured to the end of red bar. 98.4" (250 cm) with cutter head on ground.

CUTTER WHEEL SYSTEM

Dimensions:	18" diameter	45.7 cm diameter
Engagement:	Electric switch	Electric switch
Teeth:	8	8
Cutter Swing:	47"	119.4 cm
Cutter Depth:	12"	30.5 cm
Cutter Height:	22"	55.9 cm



CUTTER WHEEL

COMMITTED TO QUALITY & SERVICE

The Bandit Backbone™ Support

The Bandit Backbone is Bandit's commitment to customer service and support. It's always been a cornerstone of Bandit's philosophy, and today that backbone is stronger than ever. If you own a Bandit hand-fed chipper – regardless the age, hours, or warranty status – the Bandit Backbone is here to support you.

We Are Here to Support You

There are nearly 200 dealer locations in the US and over 60 international dealers to support you. They are factory trained. Plus we have an experienced parts and service department supporting you and our dealers.

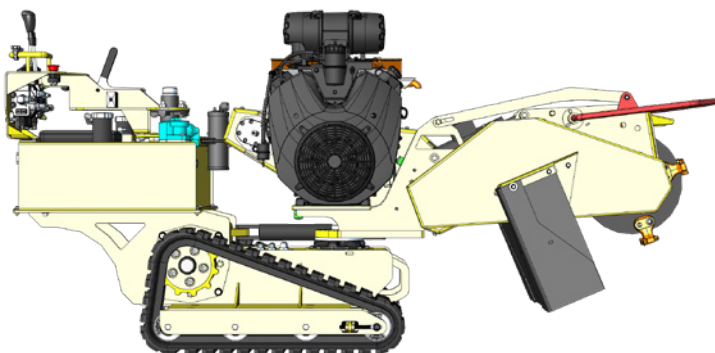

SG-40 FEATURES

- Wide 47" Cutterwheel Swing
- Powerful / Adjustable Rubber Tracks
- Pivoting Control Panel
- Precise Belt Adjustments
- Operator-Friendly Controls / Instrumentation



OPERATOR CONSOLE

Bandit Offers a Complete Line of Tree Care Equipment:
 Hand-Fed Chippers • Stump Grinders • Whole Tree Chippers
 The Beast® Horizontal Grinders • Track Carriers • Attachments