

SY390H

SANY

Quality Changes the World



IMPRESSIVELY EFFICIENT

HIGH PERFORMANCE. LOW CONSUMPTION.

CONSTRUCTION MACHINERY



CRAWLER EXCAVATOR
SY390H

Engine
CUMMINS L9-C
Rated power
252 kW / 1800 rpm
Bucket capacity
1.9 m³
Operating mass
40000 kg

SANY

For challenging tasks, you need a first-class partner

Quality comes from experience, and from new ideas. This is why we combine these two crucial factors at SANY. This is because we are one of the leading producers, having sold more than **450 000** excavators **worldwide**. This means that you can always rely on sophisticated products that have been tried and tested in practice. An impressive **5–7%** of our annual turnover is dedicated to research and development. This is why we give you not only our word, but also our extraordinary **five-year warranty** as a guarantee of how powerful and robust our products are.

450 000

EXCAVATORS SOLD
WORLDWIDE

5–7%

TURNOVER FOR RESEARCH
AND DEVELOPMENT

FIVE-YEAR WARRANTY *

Quality Changes the World

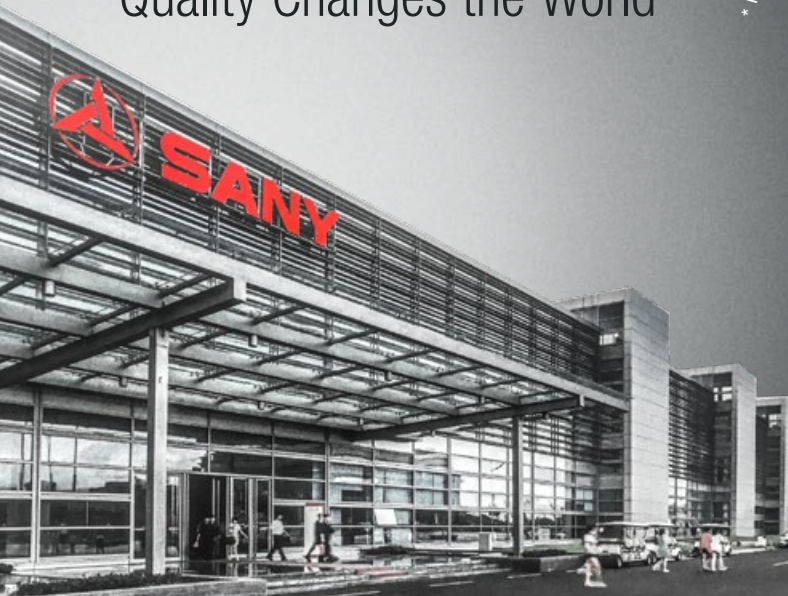

SY390H HARD FACTS

Max. bucket digging force
235 kN (ISO)

Max. arm digging force
184 kN (ISO)

Swing speed
8.9 rpm

Max. travel speed
5.4 km/h

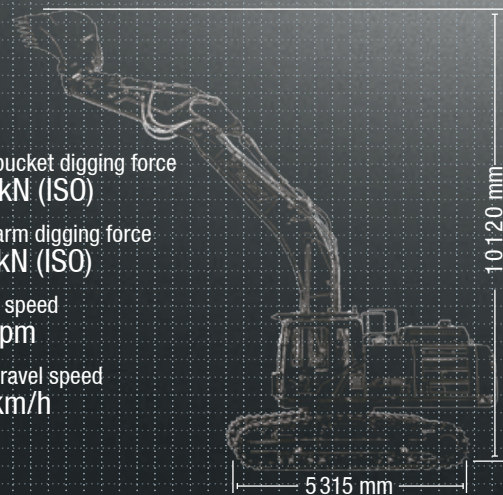

* Applicable in certain markets, please check with your local dealer.



SY390H

A NEW DIMENSION IN PRODUCTIVITY

Whether it's in civil engineering, demolition work or extraction – the SANY SY390H stands out as a sturdy all-rounder for heavy-duty applications in terms of performance, quality and robustness. In production, new technologies meet solid craftsmanship and high quality materials meet precise manufacturing methods. The result? Machines that offer you lasting and reliable productivity, and all this with an impressive price/performance ratio.



TOP PROPERTIES



COMPONENTS

SMART VENTILATION

To ensure that the engine does not overheat, even at maximum output, the SY390H is equipped with a powerful, electronically controlled fan. An integrated coupling ensures that the fan only starts to run when it is actually needed. This saves fuel, decreases noise levels and reduces emissions. Only main components from well-known brand manufacturers are used; for example, the tried and tested hydraulic system.

QUALITY

Always reliable – Optimum weight distribution was developed for the arm and boom, enabling maximum lifting capacity. New, high-strength cast parts at the points of most stress on the equipment reduce load stress and improve durability.

USER EXPERIENCE

So comfortable, so productive – The spacious cab is equipped with a comfortable, fully adjustable seat and adjustable consoles. This, along with some other features, such as the 10" touch display, makes the SY390 a comfortable workspace.

DIMENSIONS

Stable base – The heavy-duty undercarriage provides stability in any situation. It is equipped with a triple chain guard and double-bearing the top rollers as standard. Ideal conditions, for maximum service life, even with constant, heavy-duty use.



SAFETY

Looking good – Two cameras (rear and side) provide the driver with a comprehensive view of the working environment. The images from the cameras can be shown either individually or combined on the HD display. The flat bonnet also allows a clear view to the rear.

COMPONENTS

High degree of efficiency – The powerful CUMMINS unit, in combination with the corresponding exhaust treatment, guarantees full performance for every task. The drive without exhaust gas recirculation ensures efficient combustion.

ECONOMY

Maximum productivity – Select the optimum operating mode according to the specific application and choose between high performance or minimum fuel consumption. The incredible productivity is also a result of its high level of flexibility. For this reason, the SY390H is equipped with two auxiliary control circuits as standard.

DIMENSIONS

Stable in every situation

Anyone who wants to really tackle the tough everyday conditions of the construction site needs excellent stability. With the SY390H, the sturdy HD undercarriage is the perfect base. With its low center of gravity and sophisticated balance, it can make full use of its impressive capacity. A triple chain guard and two stem shoes as standard equipment complete the robust undercarriage design.



SAFETY

SAFETY DOWN TO THE TINIEST DETAIL

A rear camera and a side camera are installed ex works as standard. The images from the cameras can be displayed on the HD monitor, either individually or in various combinations, they provide an accurate image of the environment to ensure the highest level of safety. In poor lighting conditions, six work spotlights provide excellent illumination. The maintenance-free LED lights stand out thanks to their exceptional illumination and low power consumption, thereby saving the battery. Sturdy loops for secure transport and a maintenance platform with non-skid surface and a non-slip rail are included in the standard equipment along with emergency lowering. The latter allows the equipment to be lowered if the drive unit were to fail. The comprehensive safety package is completed by protective grilles on the roof and in the lower section of the cab window. These protect both persons and the machine, particularly when working on stony terrain or during demolition work.



Absolute reliability – for peace of mind!

SANY's five-year warranty* gives you the assurance that you can fully count on your equipment.

* With participating partners

QUALITY

Because quality counts

Crawler excavators are high-performance machines that have to prove themselves again and again in the tough conditions of the construction site. We therefore make no compromises when it comes to quality. Clean robot-controlled welded seams and high-quality hydraulic line piping ensure that you can rely on your SANY. In addition, the all-round reinforcement of the upper structure and the all-metal paneling protects against expensive damage – more minor damage can simply be straightened out when needed.

EFFICIENCY, COST-EFFECTIVENESS AND USER EXPERIENCE

USER EXPERIENCE

A DRIVER'S CAB THAT LEAVES NOTHING TO BE DESIRED

The SY390H cab has been designed down to the last detail to enable safe, fatigue-free operation. Its extensive insulation provides excellent protection for the driver against noise and dust. The air suspension seat is the central element - it can be adjusted in various directions and therefore allows easy access to the controls and a perfect overview. Perfect for quick and accurate operation: the consoles are connected to the seat and move along with it. Some of the other elements adding to the comfort include heated seating, automatic air conditioning, a refrigerated compartment, a radio and a USB ports.



USER EXPERIENCE

Spacious and practical

On the 10" touch display, the operator can, at any time, quickly and reliably call up the most important information and unit statuses. This includes the HD images of the two cameras fitted as standard. Simple handling, intuitive menu navigation and a choice of languages prevent incorrect operation. What 's more, you can even reliably operate the 10" touch display when wearing gloves.



USER EXPERIENCE

Simplicity is key in maintenance

Regular inspection and maintenance work ensure a good performance and service life of the machine. We therefore make these tasks as easy as possible for the operator. The lubrication block allows quick, convenient lubrication of multiple lubrication points in one operation. The air filter is easily accessed from the ground and the oil dipstick above the operator's platform.



Our highlights – the added benefits SANY offers you:

- + Large, high-resolution 10" touch display
- + 2 cameras
- + Seat with adjustable consoles
- + 2 auxiliary control lines
- + Programmable attachment devices
- + Automatic switching of the hydraulic system in hammer operation
- + Heavy Duty undercarriage and equipment
- + Very high engine power



ECONOMY

Maximize performance, minimize consumption

The water-cooled six-cylinder engine gives all the power necessary to really get stuck into excavation, quarrying or demolition. Furthermore, not only does the unit meet the strict requirements of Emission regulation Stage V, it is also extremely fuel-efficient and quiet.

ECONOMY

FLEXIBILITY AT THE PUSH OF A BUTTON

The hydraulic quick-coupler pipe work is already included exworks as standard and is incorporated into the machine. The two control circuits can be individually adjusted when using a quick hitch and the desired parameters can be saved for the respective attachment and called up at any time. The electric hammer valve makes it even easier to change attachment devices. It can be operated from the cab with the tool change and saves having to manually change over the return line in hammer operation. This function therefore facilitates the automatic change of attachment devices.



TECHNICAL SPECIFICATIONS

ENGINE

Model	CUMMINS QSL9
Type	Water-cooled, 6 cylinders, with common rail and AdBlue
Exhaust emissions	Stage V
Rated power	252 kW / 1800 rpm
Max. torque	1 526 Nm / 1 400 rpm
Displacement	8 900 ccm
Batteries	2 × 12 V / 120 Ah

HYDRAULIC SYSTEM

Main pump	2 x variable-piston-pump with electronic positive control
Max. oil flow	2 × 352 l/min
Travel motor	Variable displacement axial piston motor
Swing motor	Axial piston motor

RELIEF VALVE SETTINGS

Implement circuit	343 bar
Heavy lift circuit	343 bar
Swing circuit	310 bar
Travel circuit	343 bar
Pilot pressure	39 bar

SERVICE REFILL CAPACITIES

Fuel tank	600 l
Engine coolant	44.5 l
Engine oil	36 l
Drive (per side)	10 l
Swing drive	10.5 l
Hydraulic oil tank	415 l

PERFORMANCE

Swing speed	9 rpm
Max. travel speed	High 5.4 km/h, slow 3.2 km/h
Max. travel force	245 kN
Gradeability	35°
Bucket capacity	1.9 m ³
Ground pressure	0.7 kg/cm ²
Bucket digging force ISO	235 kN
Arm digging force ISO	184 kN

UNDERCARRIAGE AND UPPER STRUCTURE

Boom length	6 500 mm
Arm length	3 200 mm
Bottom rollers	9
Top rollers	2
Rotation device	Planetary gear reducer driven by an axial piston motor, automatic hydraulic released slewing brake

OPERATING MASS

SY390H 40 000 kg

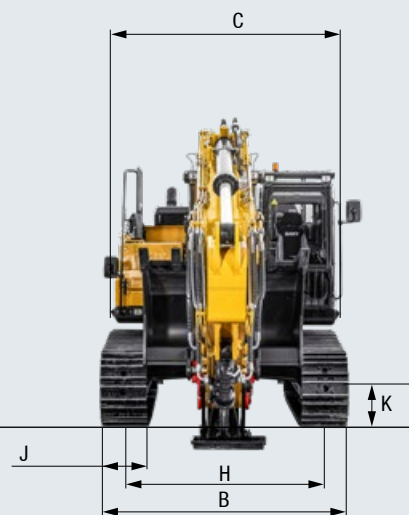

NOISE LEVEL

ISO 6395 (exterior)	106 dB(A)
ISO 6396 (interior)	73 dB(A)

LIFTING CAPACITIES*

Load point height	Radius				Max. digging reach		
	3.0 m	4.5 m	6.0 m	7.5 m	Capacity		mm
7.5 m kg					7445	7445	7508 7508 7651
6.0 m kg			7838 7838	7674 7674	7723	7420	8523
4.5 m kg		11274 11274	9313 9313	8386 8386	7958	6674	9061
3.0 m kg		14855 14855	11028 11028	9281 8499	8215	6291	9326
1.5 m kg		17214 16092	12456 11002	10093 8236	8497	6172	9340
Ground line kg		17899 15765	13244 10712	10601 8052	8809	6302	9106
-1.5 m kg	15981 15981	17531 15727	13318 10605	10642 7976	9150	6744	8601
-3.0 m kg	22155 22155	16347 15870	12638 10659	9971 8035	9513	7701	7773
-4.5 m kg	18794 18794	14113 14113	10852 10852		9851	9851	6494

*at 700 mm track pads width

BUCKET CAPACITIES

Bucket type	Arm length	3.2m	
	Boom length	6.5m	
	Bucket m ³	Counterweight	6.8t / 7.8t
Standard rock bucket	1.6		/
Standard soil bucket	1.8, 1.9, 2.1, 2.32		2.4, 3.2

Max material density: 2.1T/m³ 1.8T/m³ 1.5T/m³ 1.3T/m³
 Max hardness of the material: 9-12 5-8 3-4 1-2

DIMENSIONS

A	Transport length	11 430 mm
B	Transport width*	3 290 mm
C	Overall width of upper structure	3 105 mm
D	Height over cabin/ROPS	3 450 mm
E	Height of Boom – transport	3 780 mm
F	Overall length of crawler	5 315 mm
G	Tail length	3 550 mm
H	Track gauge	2 590 mm
I	Track height	1 123 mm
J	Track pads width	600 mm
K	Min. ground clearance	570 mm
L	Counterweight clearance	1 418 mm
M	Engine cover height	2 794 mm
N	Tail swing radius	3 550 mm
O	Center distance of tumbler	4 140 mm

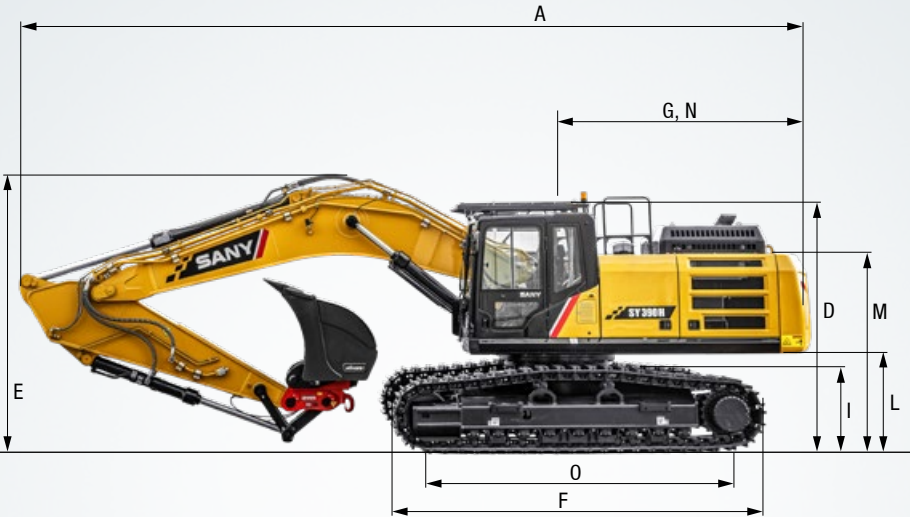

* at 700 mm track pads width

WORKING AREA

A	Max. digging reach	10 830 mm
B	Max. digging depth	7 125 mm
C	Max. digging Height	10 120 mm
D	Max. dumping height	7 490 mm
E	Min. dumping height	- mm
F	Max. vertical digging depth	6 845 mm
G	Overall height over arm by min. swing radius	8 830 mm
H	Min. swing radius	4 180 mm

* Without quick hitch

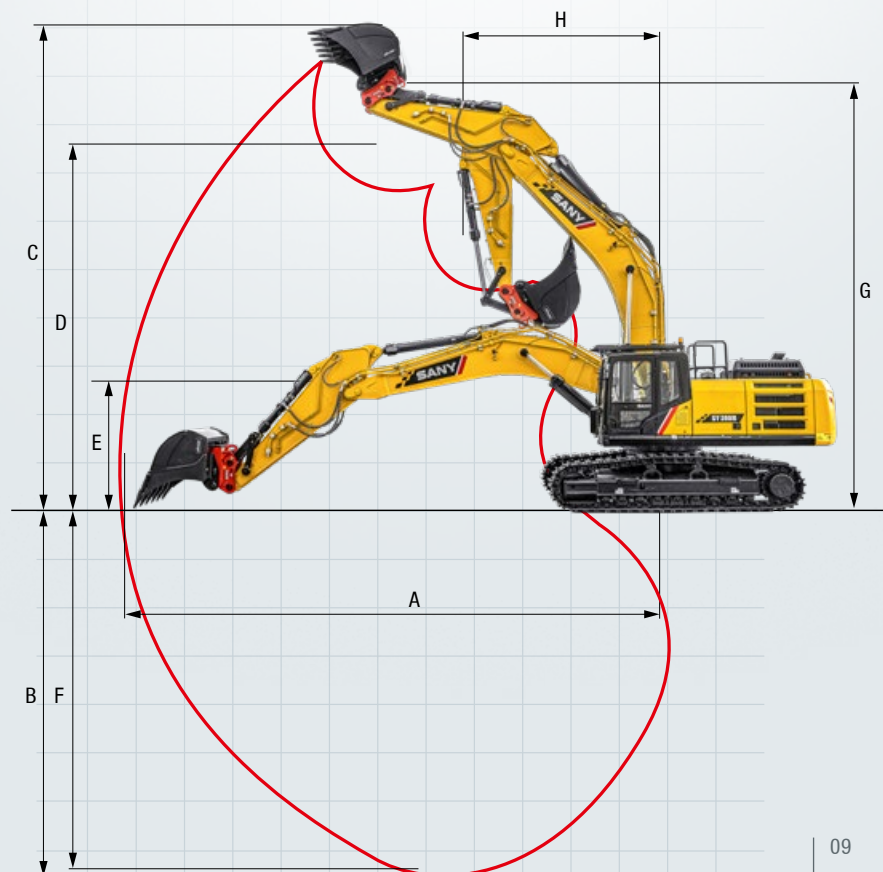

Already with many extras

The SY390H is equipped with many extras as standard. From the comfortable operator's cab to the automatic switching of the hydraulics, many features make day-to-day operation more efficient and safer.



OPERATORS COMFORT / CABIN

Automatic air conditioning	●
Radio and speaker	●
Armrests (adjustable)	●
12v outlets	●
USB port (music)	●
Heated air suspension seat	●
Sky light	●
Integrated cool box	●
10" touch display	●
ROPS/FOPS cabin with front protection	●
Rubber floor	●

WORKING EQUIPMENT

Boom and arm hose burst check valves	●
Double acting circuit for hydraulic quick coupler with piping	●
Breaker&Shear line proportional on Joystick with piping	●
Rotation line on Joystick with piping	●
Rotation line proportional on Joystick with piping	●
Flow adjustment for attachments	●
Pressure adjustment for attachments	●
Ram protection on both sides of the upper structure	●

UNDERCARRIAGE

Steel tracks 700	●
Steel tracks 600	●
Holes/loops for fixing	●
Standard equipment ● Special option ●	

The standard and special options differ depending on the country in which the crawler excavator is delivered. If you have any questions, please contact your dealer directly.

* The air conditioner contains fluorinated greenhouse gases: Refrigerant type: HFC-134a, Global warming potential: 1 430, Quantity: 0.9 kg, CO₂e: 1.29 t

WORKING LIGHTS

Lights – front (LED)	●
Lights – boom (LED)	●
Lights – platform (LED)	●
Lights – back (LED)	●

ENGINE/ENGINE COMPARTMENT

Auto idle	●
Fuel pump	●
DPF	●
DOC	●

HYDRAULIC SYSTEM

Swing brake	●
2 speed travel	●
Piping for additional hydraulic function AUX 1	●
Piping for additional hydraulic function AUX 2	●
Hydra Pre-pressure operating joysticks	●

SAFETY

Battery master switch	●
Travel Alarm	●
Warning beacon	●
Rear camera	●
Camera on right side	●
Handrails	●
Lockable hoods	●
Lockable fuel cap	●

Parts supply – quick and reliable

With the purchase of a SANY crawler excavator you have made an investment in the future. Fast availability of spare parts is your guarantee of minimal downtimes and failure times.



A SERVICE YOU CAN RELY ON

Just as we do with our excavators, we also demand high quality and reliability of our service products. This underlines our equipment's performance in terms of their durability and their excellent price-performance ratio. After all, maintenance is crucial

for efficiency, cost-effectiveness and safety. Your SANY dealer is happy to help you with a comprehensive range of services to ensure that your machine continues operating efficiently in the long term.

SANY – flexible, fast and always there for you

Rapid assistance, tailored advice and a reliable supply of original parts – that is what we mean by a premium service.



GERMANY
Cologne



The added benefits SANY offers you:

- + Fast supply thanks to the central warehouse near Cologne
- + More than 15,000 spare parts to make your machine highly reliable
- + Expert knowledge for optimal supply for your machine
- + Thanks to SANY's special training program, our dealers are always kept up to date so that they can face all technical challenges.

Detailed information in black and white

Handbooks and documents are available for all SANY crawler excavators, and these can help you with operation, maintenance, servicing and repairs. These include operating and maintenance instructions and technical specifications.





FLEXIBLE POWERHOUSE

The SY390H makes it easy for you to work efficiently, and with as much flexibility as you've always wanted. With the automatic switching of the hammer valve and the individually programmable attachment devices, even challenging attachments can be changed over quickly and easily. This makes operation more efficient and requires fewer compromises when changing tasks. A flexible powerhouse, the SY390H is a real hero at work, powering through a lot of work, wherever it is put to use.

STABLE FOUNDATION

The "H" on the SY390 stands for "Heavy Duty". The HD undercarriage is not only a guarantee of stability, even in tough conditions, but also the basis for maximum service life and maximum performance.

SO COMFORTABLE, SO PRODUCTIVE

You can feel really comfortable in this cab. Large, clearly laid out, ergonomic. With an individually adjustable seat, adjustable consoles and a large 10" touch display.

YOU CAN RELY ON

The arm and boom have been designed with optimum weight distribution for maximum lifting capacity. The areas that are subject to most stress in the tough everyday conditions of the construction site are made of high-strength cast parts. This reduces load stress and increases service life.

LOOKING GOOD

To ensure that the driver always has a clear view of the entire working environment, the SY390H has a camera installed at the rear and one on the side. The display shows the images in high definition, either individually or combined. Even the rear view is unhindered, thanks to the flat engine bonnet.

OPTIMISED EFFICIENCY

The SY390H tackles work with great power. The 252 kW CUMMINS diesel engine and powerful hydraulics stand up to even the toughest challenges, combining dynamics with precision.

MAXIMUM PRODUCTIVITY

With every job, the SY390H proves its flexibility again. For each individual task you can select the most suitable operating mode: high performance or minimum fuel consumption. Furthermore, two standard auxiliary control circuits add to its exemplary flexibility.

TECHNICAL HIGHLIGHTS

Engine	CUMMINS QSL9
Rated power	252 kW / 1 800 rpm
Max. torque	1 526 Nm / 1 400 rpm
Max. travel speed	5.4 km/h
Swing speed	8.9 rpm
Main pump	2 x variable-piston-pump with electronic positive control
Max. oil flow	2 x 352 l/min

Not all products are available in all markets. As part of our continuous improvement process, we reserve the right to modify specifications and designs without giving prior notice. The figures may contain additional options.

SANY

Quality Changes the World

SANY HEAVY MACHINERY (UK) LTD
info@sanyuk.com
www.sanyuk.com